

Saturday 06 March 2010

[RSS](#) | [Trailer](#) | [Newsletter](#) | [Advertising](#) | [Partners](#) | [Contact](#) | [Sitemap](#) | [Disclaimer](#) | [Imprint](#) |



Hello - nice to meet you.
I'm Mr. Nodig® and I'll be happy to assist you in your search.



Feb 25, 2010 **New green robot aids carbon footprint reduction in rehabilitation works**

[Send2friend](#)

[Share / Save](#)

JS Kanalrobotik GmbH of Rheinstetten, Germany, in association with its newly appointed UK and Ireland distributor, CJ Kelly Associates, recently introduced to the pipeline rehabilitation market the latest advance in robot technology. The new JS Kanalrobotik robot range is available in three models. The first model is for operations in pipe diameters from DN100 to DN150, the second from DN180 to DN300 and the third is for operations in pipes from DN250 to DN600.

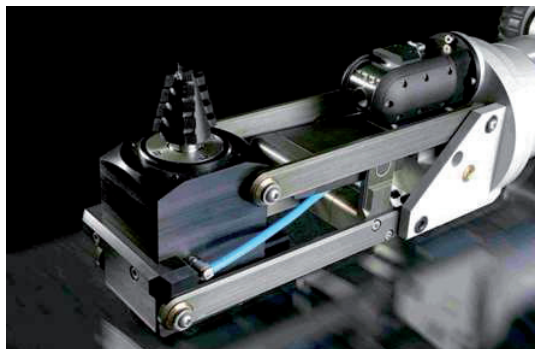

Detail of the cutter head arrangement on one of the JS Kanalrobotik units.

Operated using a Joy stick based control unit which comes with an LCD screen, image data recorder and documentation software. The robots are powered and driven through a cable drum with 100 m of 28 mm diameter hybrid cable. The units also have electric drive speed control, electric switch boxes, water pumps and a water tank which supplies water to cool the robot during cutting operations and to clean the viewing camera. The smaller robot is mounted on a tractor unit with four electric motors which are powered to 40 W. The unit can travel at variable speeds of up to 15 m/minute. The cutter head is mounted on a rotation unit with a 700o rotation capacity which sits on an extended arm with up to 125 mm of travel. The unit utilises a brushless 3-phase electric motor which requires a drive voltage of 48V. This provides a power output of up to 2,000 W at speeds up to 10,000 rpm.

The larger robot is mounted on a tractor unit again with four electric motors which are powered to 70 W. The unit can again travel at variable speeds of up to 15 m/minute and has a cutter head mounted on a rotation unit with a 700o rotation capacity, in this instance on an extended arm with up to 195 mm of travel. The unit utilises a brushless 3-phase electric motor which requires a drive voltage of 48V. This provides a power output of up to 2,500 W at speeds up to 10,000 rpm. Both units utilise a colour viewing camera with in-built LED lights which can be rotated through 270o to give the operator precise viewing and accurate control of the cutting head of either robot.

For circumstances where the pipeline under rehabilitation is not straight JS Kanalrobotik also offers the electrically powered Curve Robot system. Available for pipes of 100 and 150 mm diameter, the flexible curve robot unit the systems can negotiate and operate in pipes with 30o, 45o and 90o bends, the maximum curvature being dependent on the unit being used. The curve robot unit comes equipped with two cameras both of which use LED lighting. All three JS Kanalrobotik robots are supplied with control and power cabling that allow the systems to operate at up to 50 m from any access manhole when using the smaller curve robot and up to 100 m from the access manhole when using the larger models. If an extension lead is utilised, this distance can be extended.

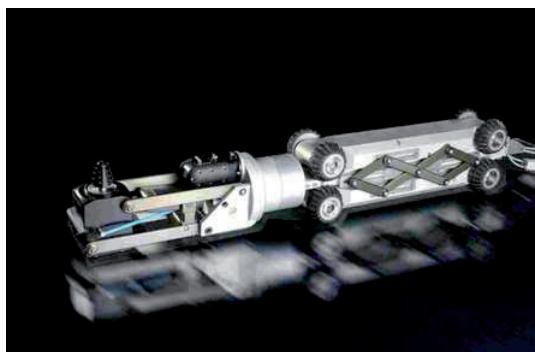

A full side view of one of the 'green' robots.

GREEN CREDENTIALS

What makes these new robots particularly innovative is their 'green' credentials. Having worked in the robotic rehabilitation industry for many years the developers of the new systems have drawn on their experience to come up with a robot that not only offers high performance but also meets the increasingly tight demands for clean use of energy. Comparing the new JS Kanalrobotik units with some of the compressed air powered or hydraulically powered systems on the market today has come up with some interesting observations. For example, for comparative performance, using the electrically driven JS Kanalrobotik system requires a power generator with just 6 kW output as compared with 15 and 30 kW respectively for hydraulic and air driven systems. Ultimately this translates into a reduction in fuel usage from as high as 4.5 l/hr for air or 2.1 l/hr for hydraulics to just 0.75 l/hr for the electrically powered option.

Furthermore, with the electric option, when the cutter is stopped and the tractor is stood still no power is used, whilst with the other options compressors and hydraulic pumps still need to operate. So the overall power consumption is reduced, ongoing potential for noise output at site is reduced and the site footprint can be reduced also with fewer pieces of equipment required to complete the job. This also brings with it the advantage that there is less equipment to be maintained during the course of



Saturday 06 March 2010

[RSS](#) | [Trailer](#) | [Newsletter](#) | [Advertising](#) | [Partners](#) | [Contact](#) | [Sitemap](#) | [Disclaimer](#) | [Imprint](#) |



Hello - nice to meet you.
I'm Mr. Nodig® and I'll be happy to assist you in your search.



Feb 25, 2010 **New green robot aids carbon footprint reduction in rehabilitation works**

[Send2friend](#)

[Share / Save](#)

JS Kanalrobotik GmbH of Rheinstetten, Germany, in association with its newly appointed UK and Ireland distributor, CJ Kelly Associates, recently introduced to the pipeline rehabilitation market the latest advance in robot technology. The new JS Kanalrobotik robot range is available in three models. The first model is for operations in pipe diameters from DN100 to DN150, the second from DN180 to DN300 and the third is for operations in pipes from DN250 to DN600.

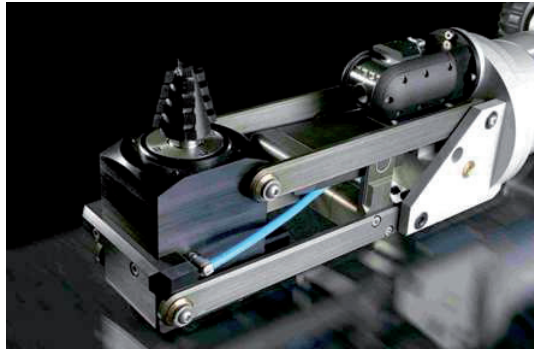

Detail of the cutter head arrangement on one of the JS Kanalrobotik units.

Operated using a Joy stick based control unit which comes with an LCD screen, image data recorder and documentation software. The robots are powered and driven through a cable drum with 100 m of 28 mm diameter hybrid cable. The units also have electric drive speed control, electric switch boxes, water pumps and a water tank which supplies water to cool the robot during cutting operations and to clean the viewing camera. The smaller robot is mounted on a tractor unit with four electric motors which are powered to 40 W. The unit can travel at variable speeds of up to 15 m/minute. The cutter head is mounted on a rotation unit with a 7000 rotation capacity which sits on an extended arm with up to 125 mm of travel. The unit utilises a brushless 3-phase electric motor which requires a drive voltage of 48V. This provides a power output of up to 2,000 W at speeds up to 10,000 rpm.

The larger robot is mounted on a tractor unit again with four electric motors which are powered to 70 W. The unit can again travel at variable speeds of up to 15 m/minute and has a cutter head mounted on a rotation unit with a 7000 rotation capacity, in this instance on an extended arm with up to 195 mm of travel. The unit utilises a brushless 3-phase electric motor which requires a drive voltage of 48V. This provides a power output of up to 2,500 W at speeds up to 10,000 rpm. Both units utilise a colour viewing camera with in-built LED lights which can be rotated through 270o to give the operator precise viewing and accurate control of the cutting head of either robot.

For circumstances where the pipeline under rehabilitation is not straight JS Kanalrobotik also offers the electrically powered Curve Robot system. Available for pipes of 100 and 150 mm diameter, the flexible curve robot unit the systems can negotiate and operate in pipes with 30o, 45o and 90o bends, the maximum curvature being dependent on the unit being used. The curve robot unit comes equipped with two cameras both of which use LED lighting. All three JS Kanalrobotik robots are supplied with control and power cabling that allow the systems to operate at up to 50 m from any access manhole when using the smaller curve robot and up to 100 m from the access manhole when using the larger models. If an extension lead is utilised, this distance can be extended.

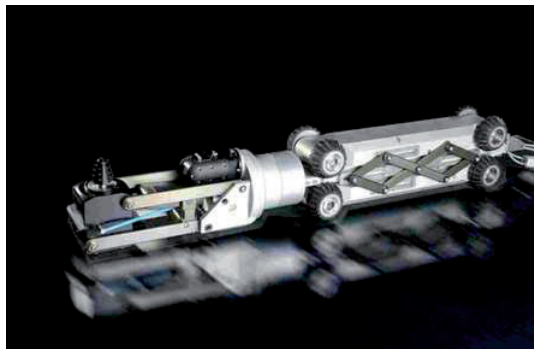

A full side view of one of the 'green' robots.

GREEN CREDENTIALS

What makes these new robots particularly innovative is their 'green' credentials. Having worked in the robotic rehabilitation industry for many years the developers of the new systems have drawn on their experience to come up with a robot that not only offers high performance but also meets the increasingly tight demands for clean use of energy. Comparing the new JS Kanalrobotik units with some of the compressed air powered or hydraulically powered systems on the market today has come up with some interesting observations. For example, for comparative performance, using the electrically driven JS Kanalrobotik system requires a power generator with just 6 kW output as compared with 15 and 30 kW respectively for hydraulic and air driven systems. Ultimately this translates into a reduction in fuel usage from as high as 4.5 l/hr for air or 2.1 l/hr for hydraulics to just 0.75 l/hr for the electrically powered option.

Furthermore, with the electric option, when the cutter is stopped and the tractor is stood still no power is used, whilst with the other options compressors and hydraulic pumps still need to operate. So the overall power consumption is reduced, ongoing potential for noise output at site is reduced and the site footprint can be reduced also with fewer pieces of equipment required to complete the job. This also brings with it the advantage that there is less equipment to be maintained during the course of



works.

Ultimately this gives two major advantages to the JS Kanalrobotik system, the first of these being that with the reduced power requirements for the same performance output the unit will contribute far less than other systems to the site's overall carbon footprint, making it a far greener option in these days of increased carbon awareness. Second is that the running costs for the electrically powered systems will be significantly less over time as compared with other options for the same cutting performance.



The JS Kanalrobotik curve robot alongside its control unit and power pack as displayed in full at a recent trade fair.

Commenting on the new JS Kanalrobotik systems, Thomas Joachim, Director of Development, said "We are very proud of our new robot range. We believe the new systems offer considerable savings both in cost to purchase and on-going cost to run for potential clients whilst offering a cutting technology that is second to none. The robots' green credentials also make them an extremely valuable addition to the increasing efforts across the industrial world to lower carbon emissions."

For CJ Kelly Associates, John Kelly, managing director said: "We have always promoted the environmental aspects of all the technologies we represent and to add the JS Kanalrobotik systems to our portfolio simply reinforces our commitment to maintaining our own environmental credentials. The pipeline rehabilitation industry has for many years strived to offer sound environmentally-friendly systems to contractors and client companies alike. Now with green systems like these new robots, even the support equipment is meeting the reduced carbon footprint challenge."

For further details please contact:

CJ Kelly Associates
 Coppice House, Main Street, Hemington, Peterborough PE8 5QJ, UK
 Tel: +44 (0)1832 293030. Fax: +44 (0)1832 293311
 Email: john@cjkelly.com
 Website: www.cjkelly.com

or

JS Kanalrobotik GmbH
 Industriestraße 9, D-76287 Rheinstetten
 Germany
 Tel: +49 7242 933344, Fax +49 7242 933345
 Email: info@js-kanalrobotik.de
 Website: www.js-kanalrobotik.de

[back](#)